

# ¿Coches híbridos y gestión empresarial?

---

Michel Hofman  
IT General Manager de TOYOTA España  
y presidente de AELIT

# Agenda

1. ¿Qué es Just In Time?
2. Hablamos de coches, de híbridos
3. Desde el coche hacia la gestión de la persona

# ¿Qué es Just in Time?

## Es un pilar del Toyota Production System

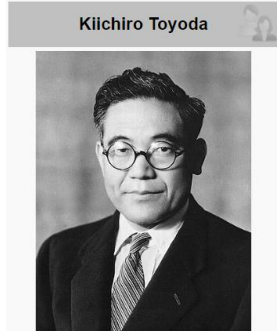

### Just in Time Pillar

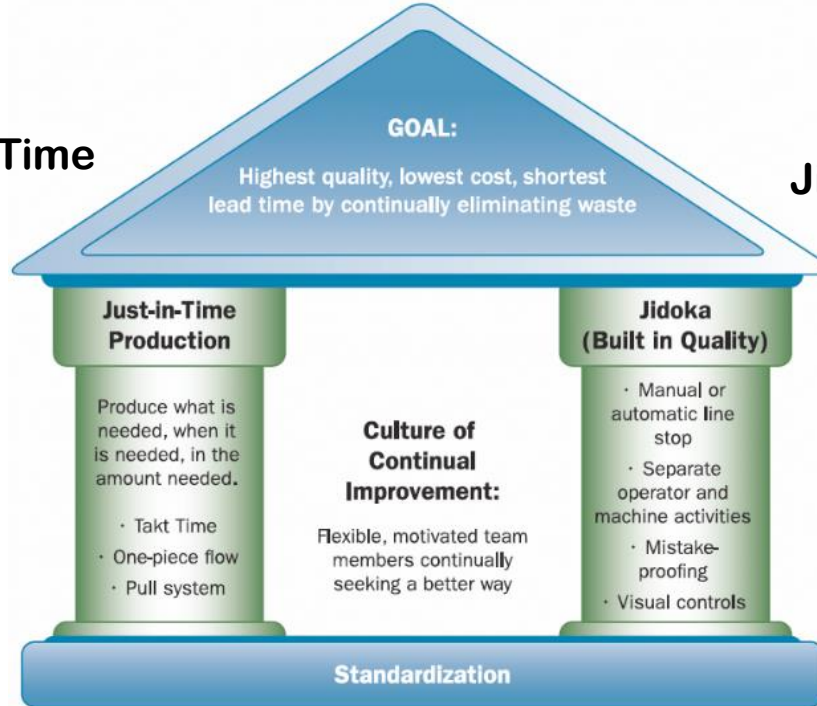

### Jidoka Pillar



# Hablamos de coches... de híbridos

**Produce**

**what is needed,**

**when it is needed,**

**in the amount that is needed**



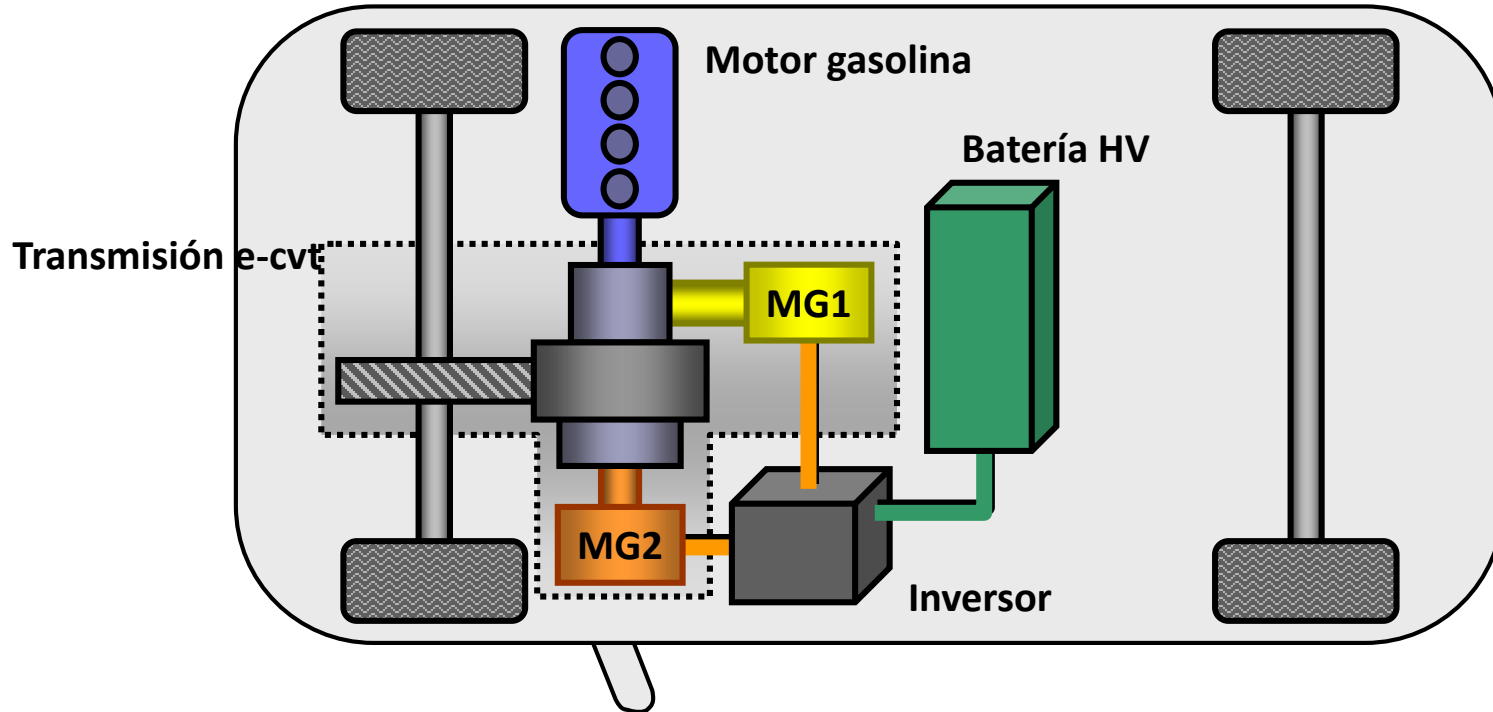



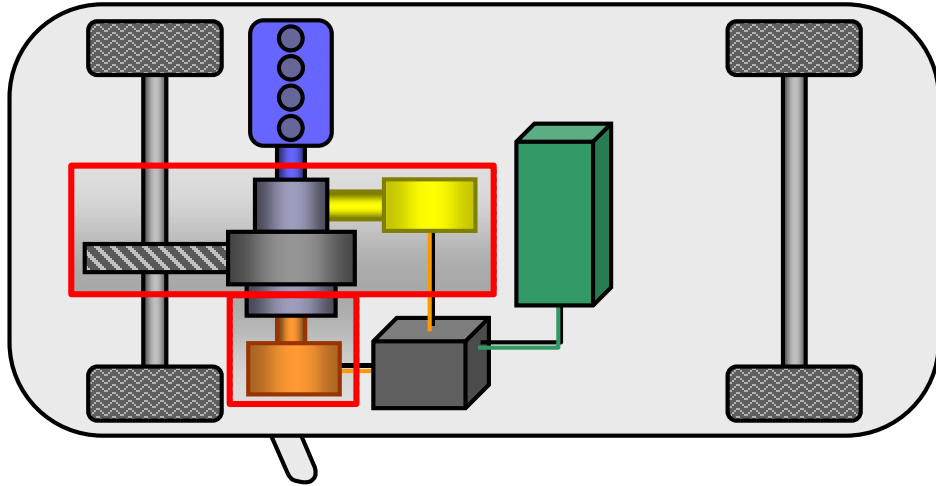

**El híbrido no tiene  
caja de cambios  
“tradicional”**

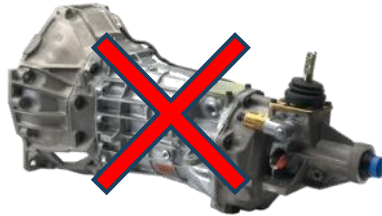

## El híbrido cuenta con

- 2 motores eléctricos
- Engranajes de reparto de potencia



## El híbrido cuenta con

Motor de gasolina

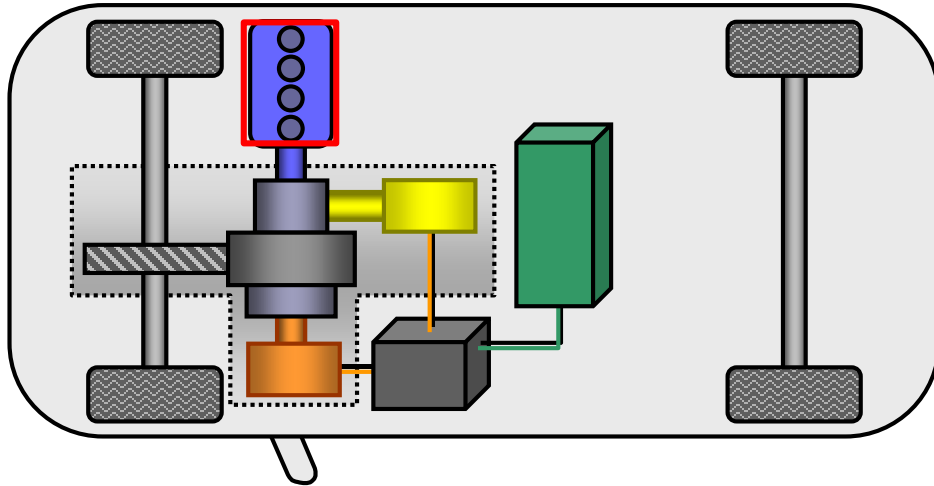

## El híbrido no tiene....

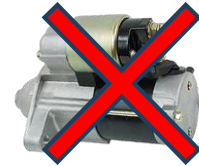

Motor de arranque

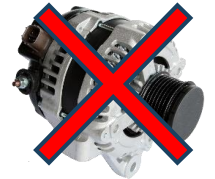

Alternador



Correa de accesorios

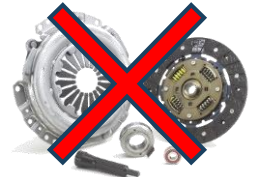

Embrague

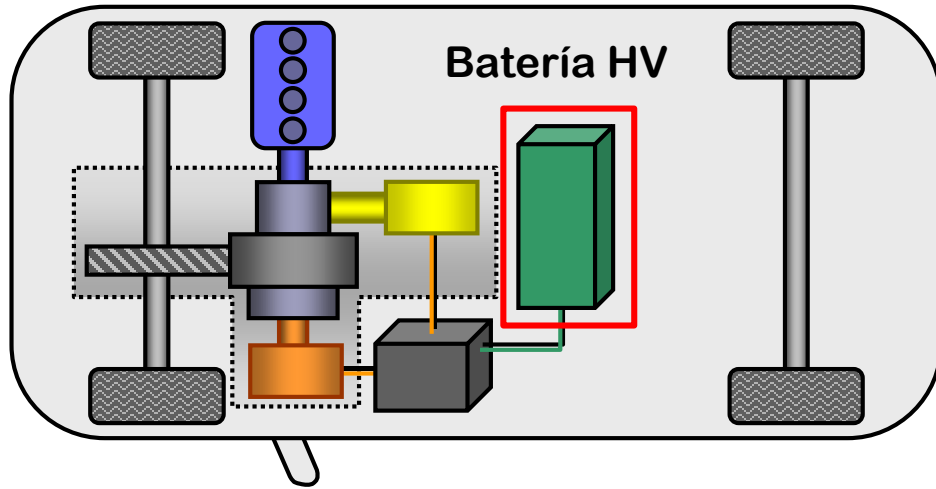

## - Engranajes de reparto de potencia



### Power Split Device

Drag the sliders to see how power from MG2 and ICE is combined. Point your mouse at the diagram for hints.

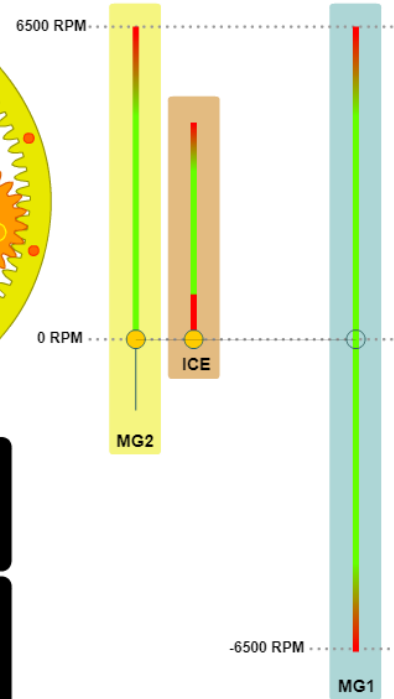
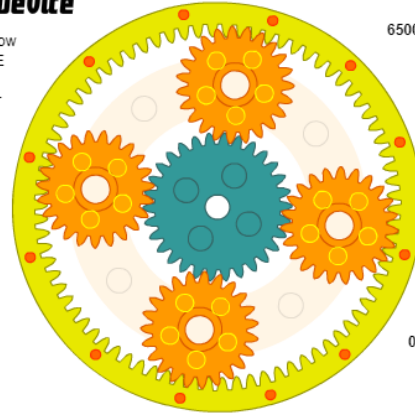

<http://eahart.com/prius/psd/>

# Desde el coche hacia la gestión de la persona

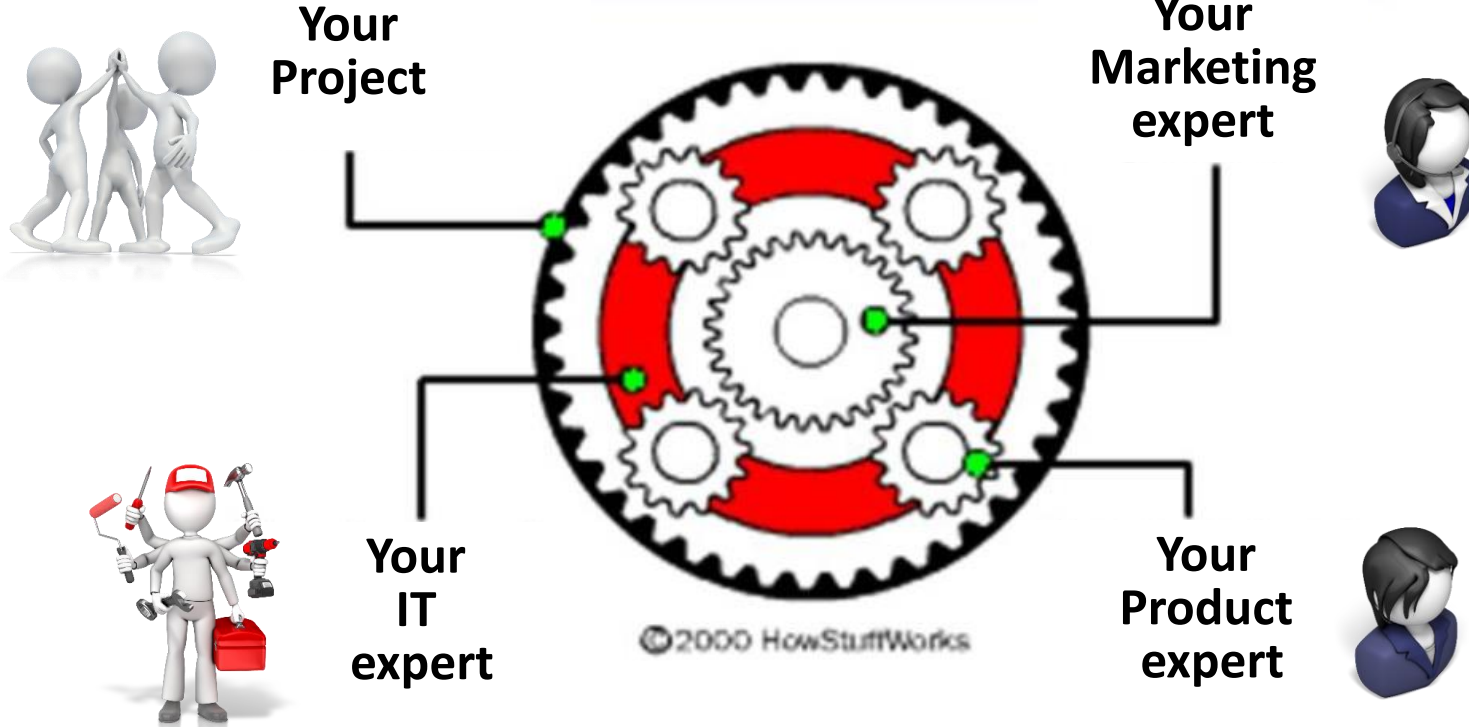

**Bienvenido al Just in Time de la persona**

**Muchas gracias**